

Listings:

- UL1778 5th Edition, 6/13/2016
- UL1741 2nd Edition, 1/28/2010 with supplement SA
- CSA22.2, No. 107.1-01 Ed:3 (R2006)

Certifications:

- HECO Rule 14 SRD
- California Rule 21 SRD
- IEEE 1547-2003
- IEEE 1547.1-2005

System Grounding and Bonding:

In this product, the PV, AC, and battery circuits are isolated from the enclosure. This product has been evaluated, listed and identified by UL to meet the requirements of 690.41 and 250.4(A) of the NEC.

- The PV system ground reference and protection is provided internal to the SkyBox, in accordance with NFPA 70 690.41(A)(6).
- The AC connections are not bonded to ground. The usual location for a neutral-ground bond is at the main AC service panel. Make sure to establish a neutral-ground bond when installing in an off-grid application.
- The battery connection is not bonded to ground. Make sure to establish a negative-ground bond for each battery system.

Equipment grounding is required by Section 250 of the National Electric Code (ANSI/NFPA 70) and Canadian Electrical Code (C22.1).

Overcurrent Protection

- The battery disconnect device in the BOS does not provide overcurrent protection. The installer must provide protection for the battery circuit according to the following parameters.
 - Maximum 175 Adc
 - Minimum 10 kA AIC
- AC overcurrent protection is provided in the BOS.



CAUTION:

To reduce the risk of fire, connect only to a circuit provided with a 60 amperes maximum branch-circuit protection in accordance with the National Electric Code, ANSI/NFPA 70.

Date and Revision

July 2018, Revision A

900-0195-01-00 REV A
©2018 OutBack Power Technologies. All Rights Reserved.

Electrical Specifications

- Maximum continuous output: 5000 VA @ 45°C
- Nominal input and output voltage: 120/240 Vac
- Nominal frequency: 60 Hz
- Maximum continuous output current: 24 Aac
- Maximum grid input current: 48 Aac
- Maximum generator input current: 48 Aac
- Maximum PV source voltage: 600 Vdc
- Operating PV source voltage range: 200 to 600 Vdc
- Maximum PV input current: 20 Adc
- Maximum PV short-circuit current: 32 Adc
- **Aux** output: 0.6 A @ 12 Vdc
- **Aux** relay: 10 A @ 240 Vac, 5 A @ 30 Vdc
- Nominal battery voltage: 48 Vdc
- Maximum battery input current: 140 Adc
- Battery input voltage range: 42 to 60 Vdc
- Charging output voltage range: 42 to 60 Vdc
- Maximum battery charging current: 100 Adc

Supported Batteries

- Lead-acid
- Various lithium-ion models

Environmental Ratings:

- Environmental Category: Type 3R
- Maximum Altitude Rating: 10,000 feet
- Maximum Ambient Temperature: 60°C

Dimensions:

- Height 47.2" (119.9 cm)
- Width 21.0" (53.3 cm)
- Depth 9.4" (23.9 cm)

Contact Information

Mailing Address: Corporate Headquarters
17825 – 59th Avenue NE
Suite B
Arlington, WA 98223 USA
Web Site: www.outbackpower.com

IMPORTANT:
Not intended for use with
life support equipment.



SKYBOX True Hybrid Energy System

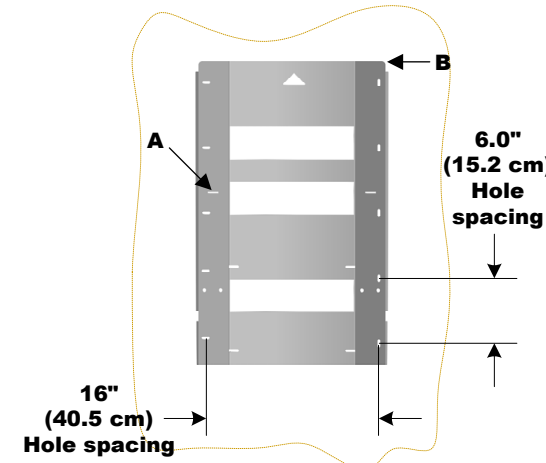

Mounting Bracket

Ensure the mounting surface is strong enough to handle three times the unit weight. Add plywood or other material as necessary to strengthen the surface.

- A** Locate this horizontal slat at about eye level for easier display viewing.
- B** Do not locate the top of the bracket more than (about) 6' (183 cm) off the floor. This ensures the SkyBox can be easily lifted onto the bracket.

Mark the placement of the bracket according to **A** and **B**, keeping in mind the dimensions in the second drawing. These dimensions show the SkyBox overlap (beyond the bracket) as well as the vertical measurements with respect to **A**. They also add the required minimum clearances of 6" (15.2 cm) to SkyBox top and sides.



IMPORTANT:

No lower clearance is shown. In outdoor installations a 36" minimum clearance above the ground or floor is required. The lower vertical measurement becomes 60.6" (153.9 cm) from **A**.

Weights:

- SkyBox: 87.7 lb (39.8 kg)
- BOS: 23.6 lb (10.7 kg)
- Mounting Bracket: 4.6 lb (2.1 kg)

Tools Needed:

- 13 mm socket (torque) wrench
- #2 Phillips (torque) driver
- Flat blade (torque) driver
- 6 mm Allen wrench
- Digital multimeter (DMM)

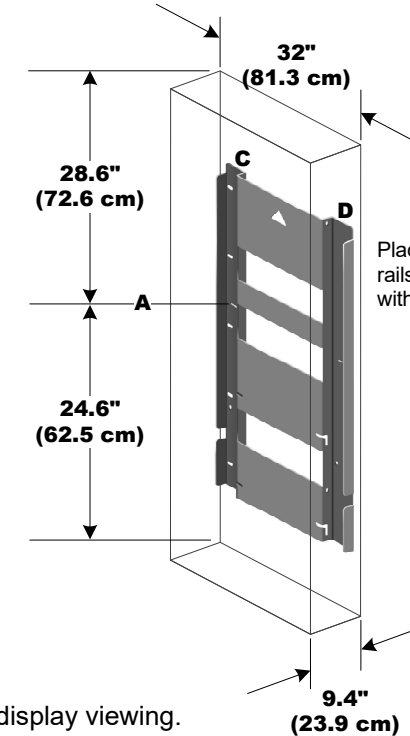

NOTE: Additional information on this product is available at www.outbackpower.com. For screen navigation, operation, and troubleshooting, see the *SkyBox Overview Guide*. For programming and applications, see the *SkyBox Programming Guide*.

Place the bracket so that rails **C** and **D** are flush with the surface.

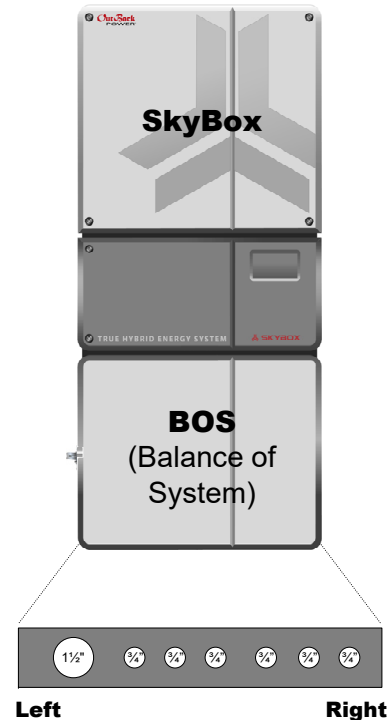

Conduit Knockouts (Underside of BOS)



WARNING: Burn Hazard

The heat sink (at the top rear of the product) may reach temperatures greater than 70°C. Install this product so that casual contact does not occur.



WARNING: Fire/Explosion Hazard

Do not place combustible or flammable materials within 12 feet (3.7 m) of the equipment. This unit employs mechanical relays and is not ignition-protected. Fumes or spills from flammable materials could be ignited by sparks.



WARNING: Personal Injury

Use safe lifting techniques and standard safety equipment when working with this equipment.



IMPORTANT:

- ❖ This document is for use by qualified personnel familiar with photovoltaic (PV) systems and maximum power point tracking (MPPT) technology as well as basic inverter functionality. Users of this document should meet all local and governmental code requirements for licensing and training for the installation of electrical power systems with AC and DC voltage up to 600 volts. This product is only serviceable by qualified personnel.
- ❖ Clearance and access requirements may vary by location. A 36" (91.4 cm) clear space in front of the system for access is recommended. *Consult local electric code to confirm clearance and access requirements for the specific location.* If this product is installed or used in a manner other than specified, the protection it provides may be impaired.
- ❖ Fuses are not to exceed maximum output rating.
- ❖ When installed outdoors, use only UL514B-compliant wet location or rain-tight conduit hubs for entry into the enclosure.
- ❖ See **Specifications** for instructions on system grounding and bonding.

Mounting

Mounting

1 Attach the wall bracket. Center the mounting holes on wall studs. Six $\frac{1}{4}$ - 20 x $1\frac{1}{2}$ " lag screws and washers are provided. Any of the mounting holes can be used. Observe all mounting considerations (page 1), including the display location (A).

2 Place the rear brackets on the BOS studs (B). Attach the rear brackets to the BOS assembly using the four M6 nuts provided (C). Ensure that the pegs on each bracket (D) face inward (toward the opposite bracket).

3 Place the BOS assembly on the wall bracket by seating the pegs (D) in the slots (E).

4 The wall bracket has securing holes for the BOS (F). Secure the BOS by inserting an M6 x 40 mm screw on each side.

5 Install the SkyBox onto the wall bracket by lifting it into position. The SkyBox is equipped with rear brackets which are already attached (G). **NOTE:** Two holes are available at the top of the SkyBox (H). A metal pipe, rod, or bar can be inserted across the top to assist with handling and lifting.

6 Insert the rear brackets into the designated slots (I) on the wall bracket. Once the SkyBox is seated, the lifting bar can be removed.

7 The wall bracket has securing holes for the SkyBox (J). Secure the SkyBox in place by inserting an M6 x 40 mm screw on each side.

Mounting is complete. See the Commissioning section.

Wiring Access

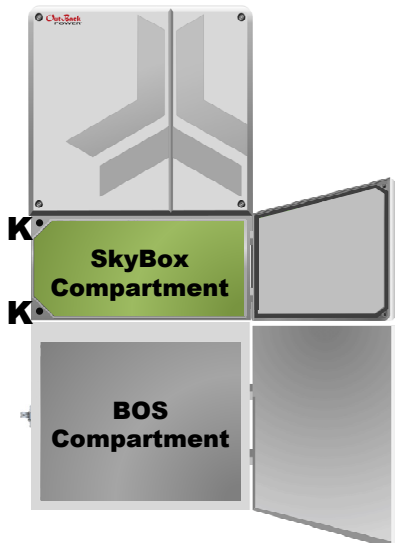

Two areas house the system wiring. The BOS compartment opens with a latch. It connects to external wiring (battery, AC, PV, etc.) and conduit. These connections extend from the BOS into the SkyBox compartment, which opens with two Allen screws (K). If the SkyBox must be removed for service, the BOS and its wiring can remain. Some connections, such as communications, pass through the BOS to be made directly in the SkyBox.

Battery Cable Connections

NOTE: The spring lock washer used in these connections must be installed with the rounded (convex) side facing outward. Installing in any other orientation will result in inadequate compression which may be hazardous. See the **CAUTION** to the far right.

Table 1: Wires and Conductors

	Permitted Sizes		Torque Requirements	
	AWG	mm ²	In-lb	Nm
Battery	2/0 to 4/0	70 to 120	65 to 75 in-lb	7.3 to 8.5 Nm
AC	#8 to #3	6 to 25	18 to 22 in-lb	2.0 to 2.5 Nm
PV	#18 to #4	1.5 to 25	11 to 16 in-lb	1.2 to 1.8 Nm
AUX	#24 to #16	0.25 to 1.5	N/A	N/A
Neutral, Ground, and PV Ground	#14 to #10	2.5 to 4	20	2.3
	#8	6 to 10	25	2.8
	#6 to #3	16 to 25	35	4.0
	#2	35	40	4.5
	#1 to 1/0	50	50	5.7

IMPORTANT
All PV, AC, and battery conductors must be copper-only and rated at 75°C.

CAUTION: Fire Hazard
Before energizing, confirm that all battery terminal hardware is installed as shown below. Stacking the terminal hardware in any other order can overheat the terminals.

CAUTION: Equipment Damage
When connecting to the battery terminals, make sure to observe the proper polarity. Connecting the cables incorrectly can damage or destroy the equipment and void the product warranty.

Wiring

NOTES

- ❖ Make connections in the order indicated. If steps or connections are not applicable, they can be skipped.
- ❖ Tighten the applicable connections to the torque values specified in Table 1. (See opposite sheet.)
- ❖ Do not connect the PV positive (+) or negative (-) conductors to ground.
- ❖ Perform all wiring in accordance with Article 690 of the National Electric Code.

10a and **10b**: Connect ground wires for battery, AC, PV, and additional PV equipment.

1a: Connect to SkyBox negative (-) **1b**, then connect to battery negative (-).

7a and **8a**: Connect PV array negative (-) and positive (+) wires. Use terminals **7b** and **8b** for a second array, if present.

6: Connect all AC neutral wires.

10c: Connect SkyBox ground wire to **10a** in BOS.

12: Ensure the rapid shutdown jumper or device **19** is installed into **Aux** terminals. Remove the factory jumper before installing an external device. Route the wires through channel **13**.

NOTE: The SkyBox will not function unless one of these is installed. It will show a **Rapid Shutdown** fault.

3c, **4c** and **5c**: Connect to the matching sockets in the wiring compartment.

7c: Connect SkyBox PV negative (-) wire to **7d**. Do not remove the jumper cap.
NOTE: **7d** is on the opposite side of the switch from **7a** and **7b**.

8c: Connect SkyBox PV positive (+) wire to **8d**. Ensure that all four screws at this location are tight.

9: Connect AFCI cable assembly to SkyBox socket **9a**.

2a: Connect to battery positive (+).

2b: Connect to SkyBox positive (+) **2c**.

5a and **5b**: Connect to load subpanel L1 and L2 respectively.

3a and **3b**: Connect to utility grid L1 and L2 respectively.

4a and **4b**: Connect to generator L1 and L2 respectively.

12: If current transducers (CT) are in use, install the wires into **Aux** terminals. Route the wires through channel **13**. These are usually installed at the utility grid input to the main AC panel.

16: Connect internet cable to SkyBox port **16a**. Route through channel **13**.
NOTE: Do not connect this cable to the other ports on the display.

15: For batteries with a separate battery management system (BMS): The BMS (CAN bus) adapter cable converts the RJ45 cable end to RJ11. It connects to the **BAT MON** port **15a**. Do not insert the RTS or any other RJ11 cable into the **BAT MON** port.

14: If a BMS is not present: Connect the remote temperature sensor (RTS). Place the sensor on the battery sidewall, as close to the center of the bank as possible.

18: Connect generator start wires into **Aux** terminals **12**. (See the key to the right.) Route through channel **13**.

17: To stack an additional SkyBox, use a CAT5 cable to connect to the **WALL** (RS-485) port **16a** on the next SkyBox. The last SkyBox in sequence has nothing connected to **17**, marking it as the end unit. (See the **NETWORK** tab in the *SkyBox Programming Guide* for additional steps.)

DC LEGEND	
Negative	—
Positive	+
Ground	⊕

AC LEGEND	
Neutral	N
HOT L1	L1
HOT L2	L2
Ground	⊕

COMMUNICATIONS LEGEND	
RTS	Gen Start (AUX)
RJ45	Rapid Shutdown
AFCI	CT (L1)
BMS	PV Cable

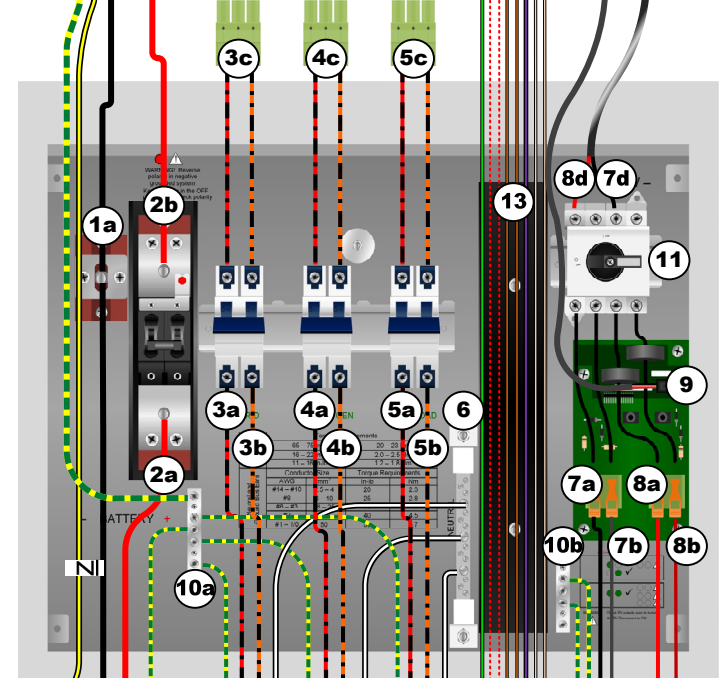
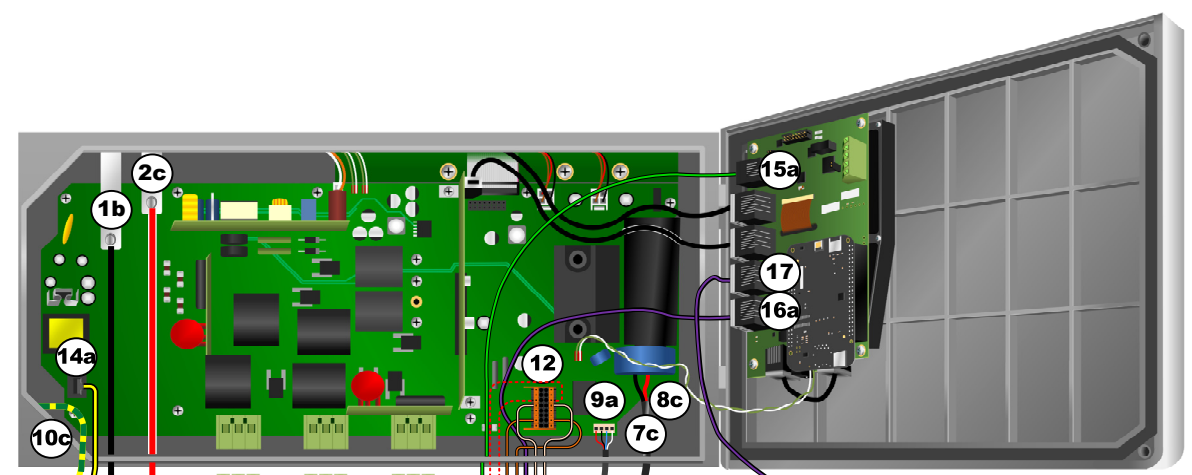

Next SkyBox

Unused	1	9	Unused
XCT L2 GND	2	10	XCT L2 HIGH
XCT L1 GND	3	11	XCT L1 HIGH
RSD INPUT 1	4	12	RSD INPUT 2
RSD OUTPUT 1	5	13	RSD OUTPUT 2
Unused	6	14	Unused
AUX RELAY 1	7	15	AUX RELAY 2
Aux 12V GND	8	16	Aux 12V

Connections for current transducers on L1 and L2 AC inputs. (Only L1 is shown in the image to the left.) **10** and **11** are for hot wires; **2** and **3** are ground. See the *Programming Guide*.

Rapid shutdown inputs (**4** and **12**). These terminals connect to normally-closed dry contact terminals on the RSI (Rapid Shutdown Initiator). Use OutBack's ICS Plus or an equivalent RSI system. See the RSI literature and the *SkyBox Overview Guide* (Troubleshooting section) for instructions if rapid shutdown occurs.

Rapid shutdown outputs (**5** and **13**). These are used to duplicate the RSD connection and function for an additional SkyBox. They should be wired to terminals **4** and **12** on the next SkyBox.

Auxiliary (Aux) dry contacts (**7** and **15**) or 12-volt contacts (**8** and **16**, up to 0.6 Adc) can serve as a switch for Advanced Generator Start. (See the *SkyBox Programming Guide*.)

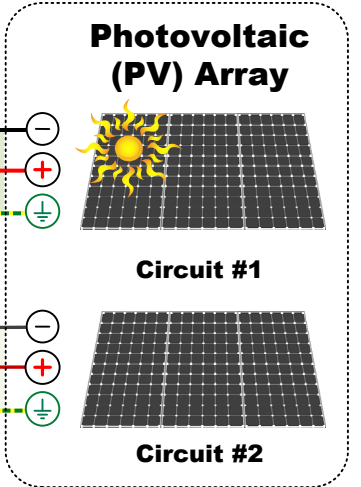
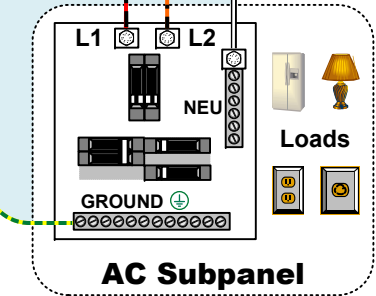
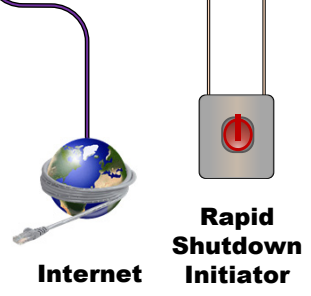
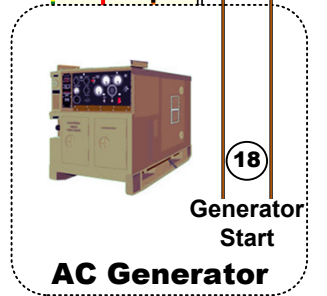
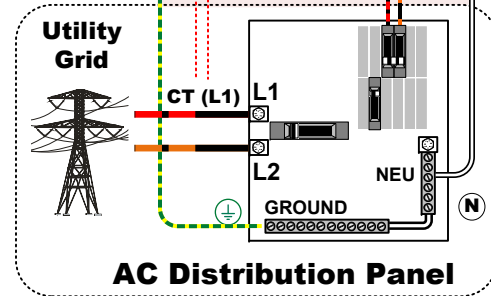
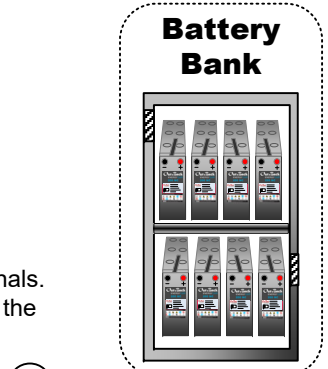

NOTE: In off-grid installations, ensure the neutral and ground are mechanically bonded. DO NOT establish more than one bond.

Commissioning



NOTES

If any onscreen faults or other problems occur during commissioning, see the Troubleshooting section of the *SkyBox Overview Guide*.

Pre-startup Procedures:

1. Double-check all wiring connections. Using a digital multimeter (DMM), test for continuity between **(6)** and **(10)**. Ensure a neutral-ground bond is installed in the system.
2. Inspect the enclosure. Ensure no debris or tools were left inside.
3. Ensure all AC loads at the backup (or protected) load panel are disconnected.
4. Ensure all AC input feeds to the BOS are disconnected at each source.
5. Using a Phillips screwdriver, remove the clear plastic (dead front) panel (not depicted). The four required screws are marked with **✖** in the image to the right.
6. Energize the system as below. Follow the procedures which are applicable to the system. If any elements are not present (including batteries, PV, or a generator), ignore those procedures.

To energize the Skybox:

1. **If batteries are present:** Verify input 48 Vdc using a DMM by measuring from **(1a)** to **(2a)**.
If batteries are not used in this system, skip to step 6.

Confirm the correct battery voltage and polarity. If the red LED indicator **(1c) is lit, the polarity is reversed. Do NOT turn on the circuit breaker.**

2. Once proper voltage and polarity are confirmed, turn on (close) the main battery circuit breaker **(2)**.



CAUTION: Equipment Damage

Incorrect battery polarity will damage the equipment.

3. On the first power-up, a welcome message is shown. The right arrow \rightarrow proceeds to the Setup Wizard. This steps through language, region, and similar changes, then PV, battery, and AC settings. On the last screen, the **Save** key proceeds to the Home screen. (The Home screen appears after every subsequent power reset.)

4. From the Home screen, turn on the SkyBox with the **ON/OFF** key \odot .

NOTE: Do not close the **LOAD** circuit breaker **(5)**.

5. Using a DMM, verify the inverted **L1** output 120 Vac on the upper **LOAD** terminals from **(5c)** to **(6)**. Verify **L2** by measuring from **(5d)** to **(6)**.
6. Verify 240 Vac across the **LOAD** terminals by measuring from **(5c)** to **(5d)**.
7. Turn on (close) the **LOAD** circuit breaker **(5)**. Do not connect loads at the protected load panel.
8. Verify 120 Vac on **LOAD L1** by measuring with a DVM from **(5a)** to **(6)**. Verify **L2** by measuring from **(5b)** to **(6)**.
9. Verify 240 Vac across the **LOAD** terminals by measuring from **(5a)** to **(5b)**.
10. Connect and test loads at the protected load panel.
11. **If grid is present:** Turn on the grid connection to the BOS at the source.
12. Verify 120 Vac on **GRID L1** by measuring with a DVM from **(3a)** to **(6)**. Verify **L2** by measuring from **(3b)** to **(6)**.
13. Verify 240 Vac across the **GRID** terminals by measuring from **(3a)** to **(3b)**.

1c Caution



CAUTION: Reverse polarity in negative grounded system
Keep breaker in the OFF position and check polarity

Setup Wizard (entry screen)

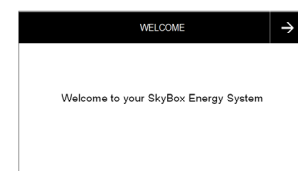

Setup Wizard (final screen)

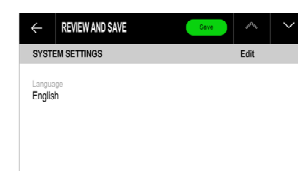

Home Screen

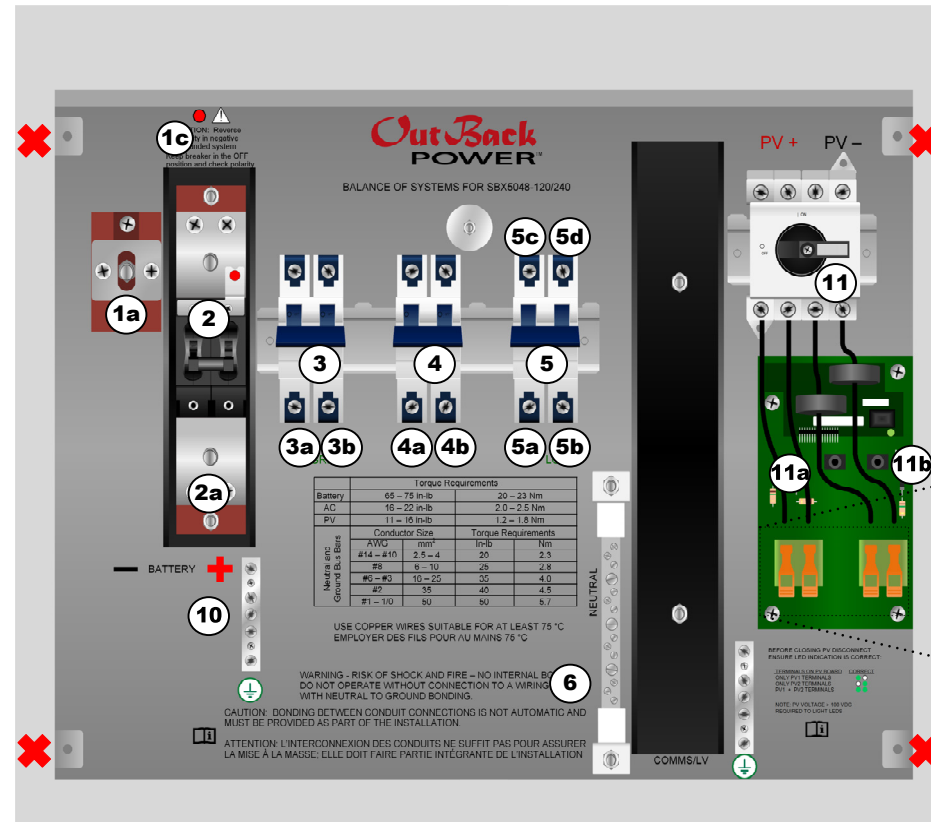
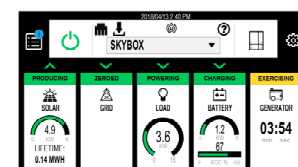

11a 11b PV LED Legend

BEFORE CLOSING PV DISCONNECT ENSURE LED INDICATION IS CORRECT:

TERMINALS ON PV BOARD	CORRECT
ONLY PV1 TERMINALS	● ○
ONLY PV2 TERMINALS	○ ●
PV1 + PV2 TERMINALS	● ●

NOTE: PV VOLTAGE > 100 VDC REQUIRED TO LIGHT LEDS

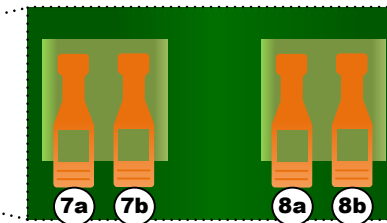

14. Turn on (close) the **GRID** circuit breaker **(3)**. The Wizard will appear for the first time if no batteries are installed. (Perform steps 3 through 10 if this is the case.) The SkyBox transfer relay should click and the **GRID** tile should read **PASS THROUGH**.
15. Using a DMM, test the pass-through (transferred) **L1** output voltage at **(5c)** and **(6)**. Test the **L2** voltage at **(5d)** and **(6)**.
16. **If PV is present:** Verify that the input is in the correct range of open-circuit voltage. Confirm polarity by measuring with a DVM from **(8a)** to **(7a)** (referred to as PV1 in the legend above). Confirm polarity from **(8b)** to **(7b)** (PV2, if present).
17. Check the green LED indicators **(11a)** and **(11b)**. If a single PV input is installed, one indicator should light. If two strings are installed, both should light. **Any other behavior means the polarity may be reversed. Do NOT turn on the switch.** Review all PV connections.



CAUTION: Equipment Damage

Incorrect PV polarity will damage the equipment.

18. Turn on (close) the PV switch **(11)**. Check indicators **(11a)** and **(11b)** again. Both indicators should light. **Any other behavior means the polarity at the top of the PV switch may be reversed.**
19. On the Home screen, check the **SOLAR** tile (as shown to the right) and ensure it is operating normally. The SkyBox will connect to the PV source if the voltage is above 250 Vdc. (See the *Overview Guide* for more information.)
20. **If a generator is present:** Turn off (open) the **GRID** circuit breaker **(3)**.
21. Start the generator. Do not turn on (close) the **GEN** circuit breaker **(4)**. Repeat steps 12 and 13 using **(4a)**, **(4b)**, and **(6)**.
22. Turn on (close) the **GEN** circuit breaker **(4)**. Repeat step 14. The **LOAD** circuit breaker may remain on (closed).
23. Stop the generator.
24. Turn on (close) the **GRID** circuit breaker **(3)**. Wait for the programmed connection delay to elapse. Test any grid-interactive functions.

To de-energize or shut down the system:

There is no required shutdown order. It is common to de-energize circuits in the reverse order from which they were energized.



WARNING: Shock Hazard

Before performing maintenance, all sources (battery, PV, and AC) must be completely de-energized. All the unit to rest for at least five minutes.

