

Single-phase Hybrid Inverter

Quick Installation Guide

HYS-7.6LV-USG1
HYS-9.6LV-USG1
HYS-11.5LV-USG1

1 General Declaration

- The information in this quick installation guide is subject to change due to product updates or other reasons.
- This guide cannot replace the product labels or the safety precautions in the user manual unless otherwise specified. All descriptions here are for guidance only.
- Before installations, read through the quick installation guide and the user manual to learn about the product and the precautions.
- All installations should be performed by trained and knowledgeable technicians who are familiar with local standards and safety regulations.
- Check the deliverables for correct model, complete contents, and intact appearance. Contact the manufacturer if any damage is found or any component is missing.
- Use insulating tools and wear personal protective equipment when operating the equipment to ensure personal safety. Wear anti-static gloves, clothes, and wrist strips when touching electron devices to protect the inverter from damage. The manufacturer shall not be liable for any damage caused by static electricity.
- Strictly follow the installation, operation, and configuration instructions in this guide and user manual. The manufacturer shall not be liable for equipment damage or personal injury if you do not follow the instructions.
- All cables in this article are copper cables.

2 Packing List

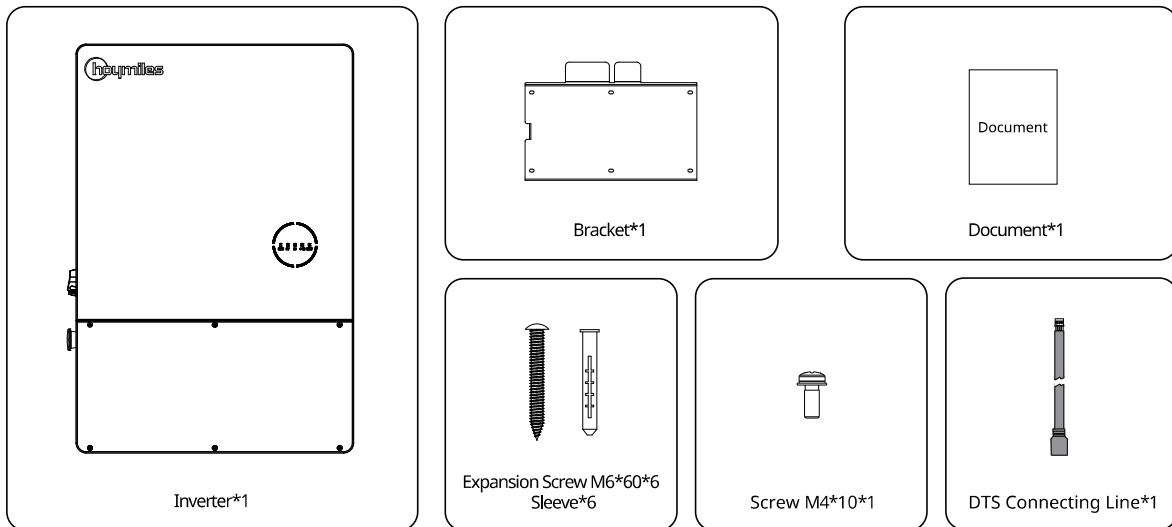

Accessories Packing List

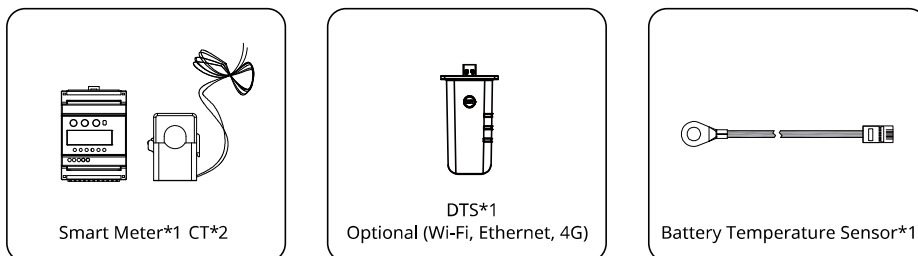

3 Dimensions

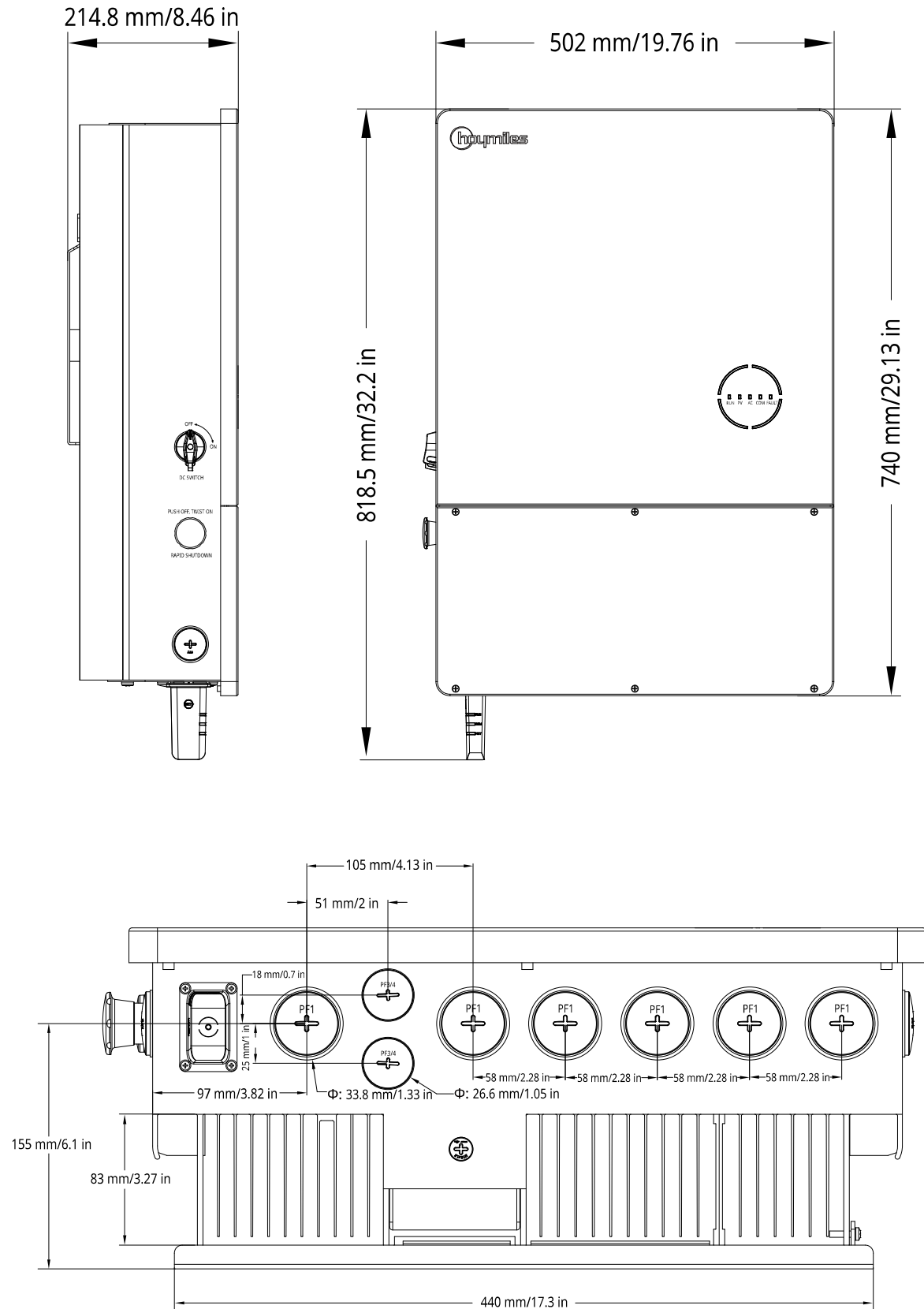

4 Wall Mounting Steps

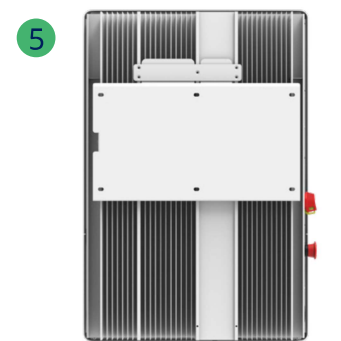
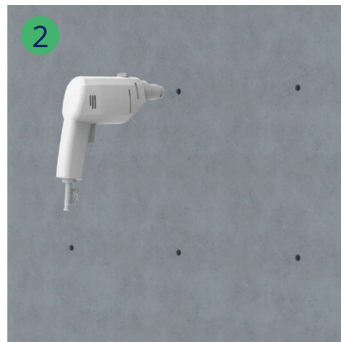
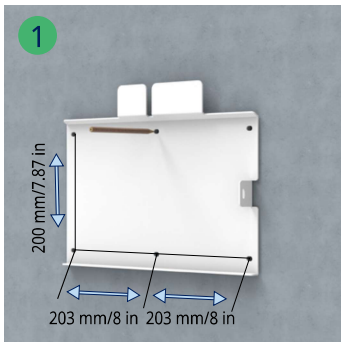
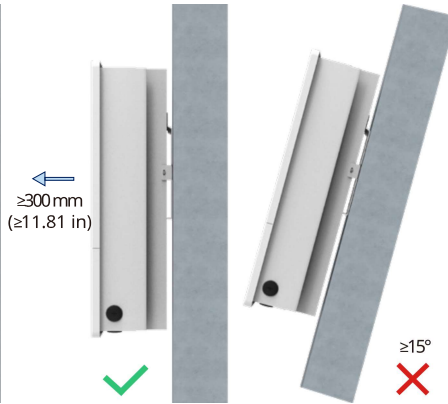
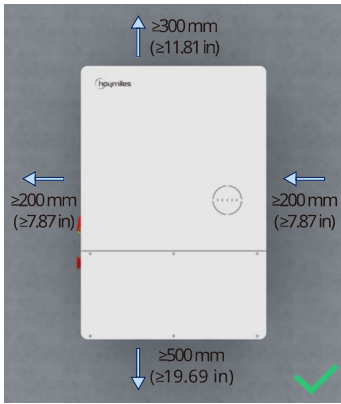

5 Wiring Diagram

Wiring diagram for North America. Please follow local wiring regulations.

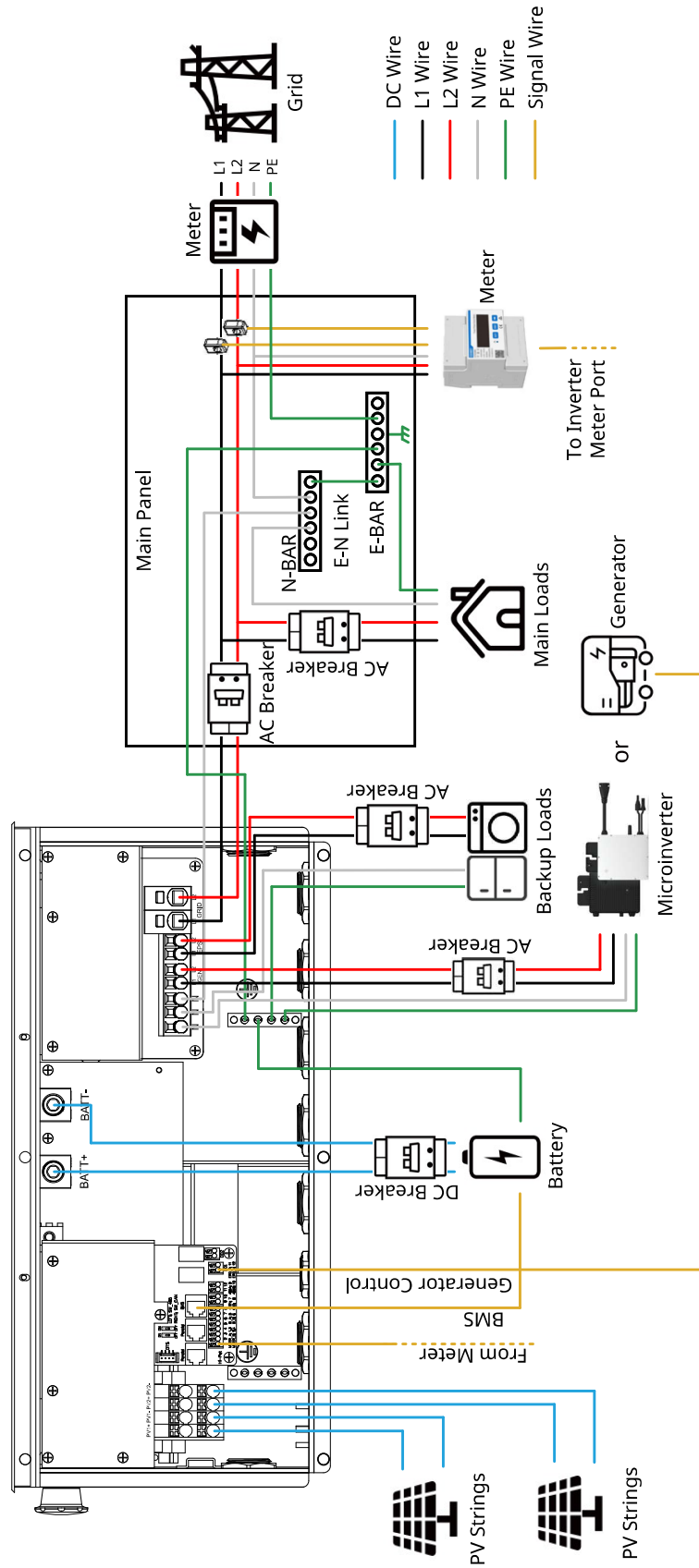

6 Recommended Cable List

This data is the cable specification recommended by Hoymiles. For proper cable specifications, please refer to local laws and regulations and actual installation.

Cable	Specification			Stripping Length
	HYS-7.6LV-USG1	HYS-9.6LV-USG1	HYS-11.5LV-USG1	
(90°C/194°F, Copper)	HYS-7.6LV-USG1	HYS-9.6LV-USG1	HYS-11.5LV-USG1	HYS-7.6/9.6/11.5LV-USG1
PV Cable	12 AWG	12 AWG	12 AWG	14 mm/0.55 in
Battery Cable	3/0 AWG	4/0 AWG	4/0 AWG	23 mm/0.91 in
Battery Ground Cable	6 AWG	6 AWG	6 AWG	12 mm/0.47 in
GRID L1/L2 Cable	4 AWG	3 AWG	3 AWG	24 mm/0.94 in
Grid N Cable	10 AWG	8 AWG	8 AWG	18 mm/0.71 in
GRID Ground Cable	8 AWG	8 AWG	8 AWG	12 mm/0.47 in
EPS/GEN L1/L2/N Cable	10 AWG	8 AWG	8 AWG	18 mm/0.71 in
EPS/GEN Ground Cable	8 AWG	8 AWG	8 AWG	12 mm/0.47 in
Communication Cable	24 AWG	24 AWG	24 AWG	8 mm/0.31 in

7 Electrical Connection

Step 1 Opening the Wiring Box Cover

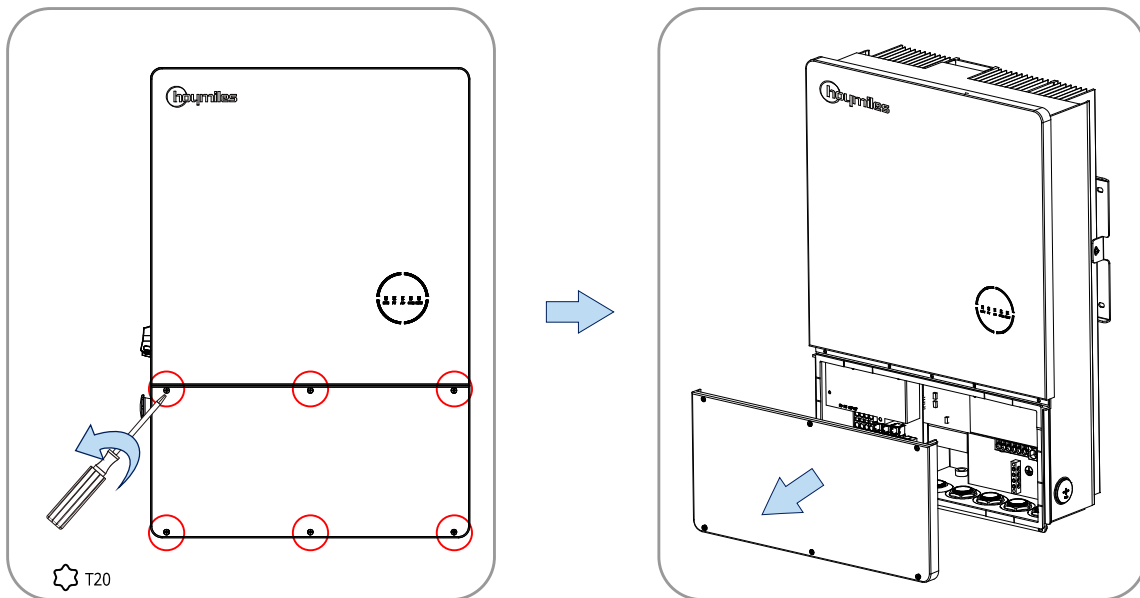

Product Overview

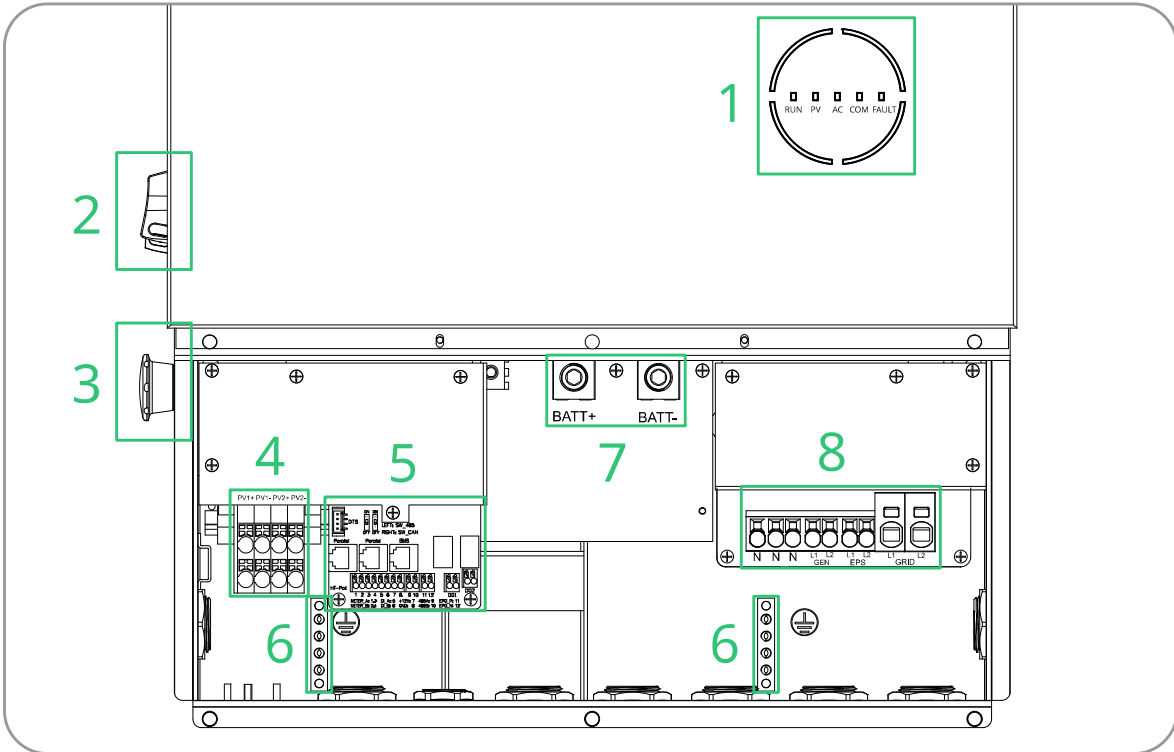

- | | | | |
|-------------------|--------------------------|-----------------------|----------------------|
| 1. LED Indicators | 3. Rapid Shutdown Switch | 5. Communication Port | 7. Battery Terminals |
| 2. DC Switch | 4. PV Terminals | 6. Grounding Bar | 8. AC Terminals |

Step 2 PV Cable Connection

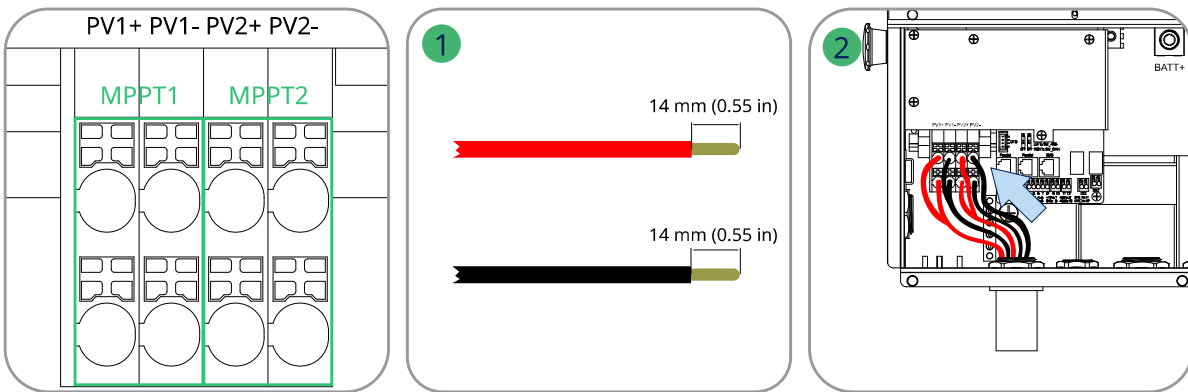

Step 3 Battery Cable Connection

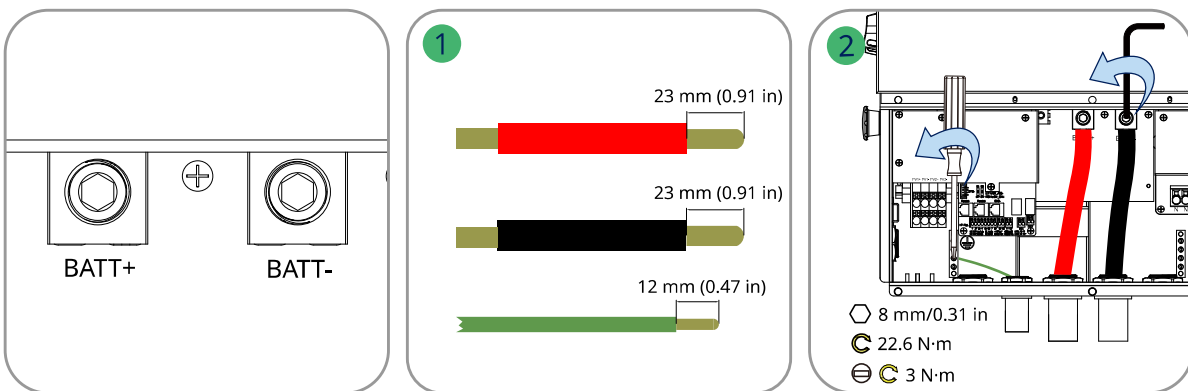

Step 4 AC Cable Connection

The following diagrams are examples of connecting grid cables, and the GEN and EPS connection methods are the same as grid connection. For recommended cable specifications of EPS and GEN, please refer to the recommended cable list mentioned above.

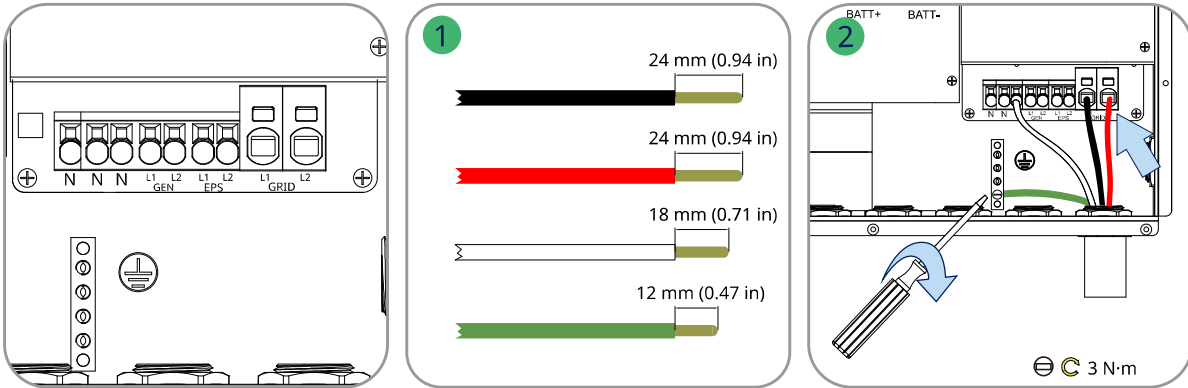

Step 5 Communication Cable Connection

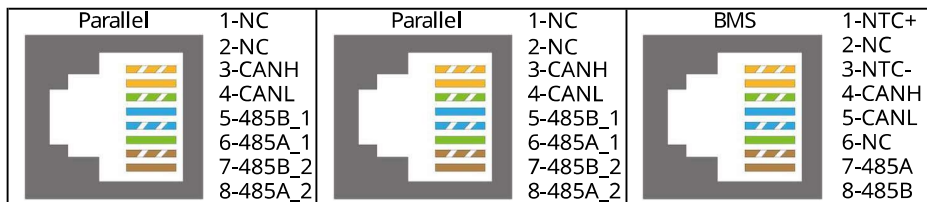
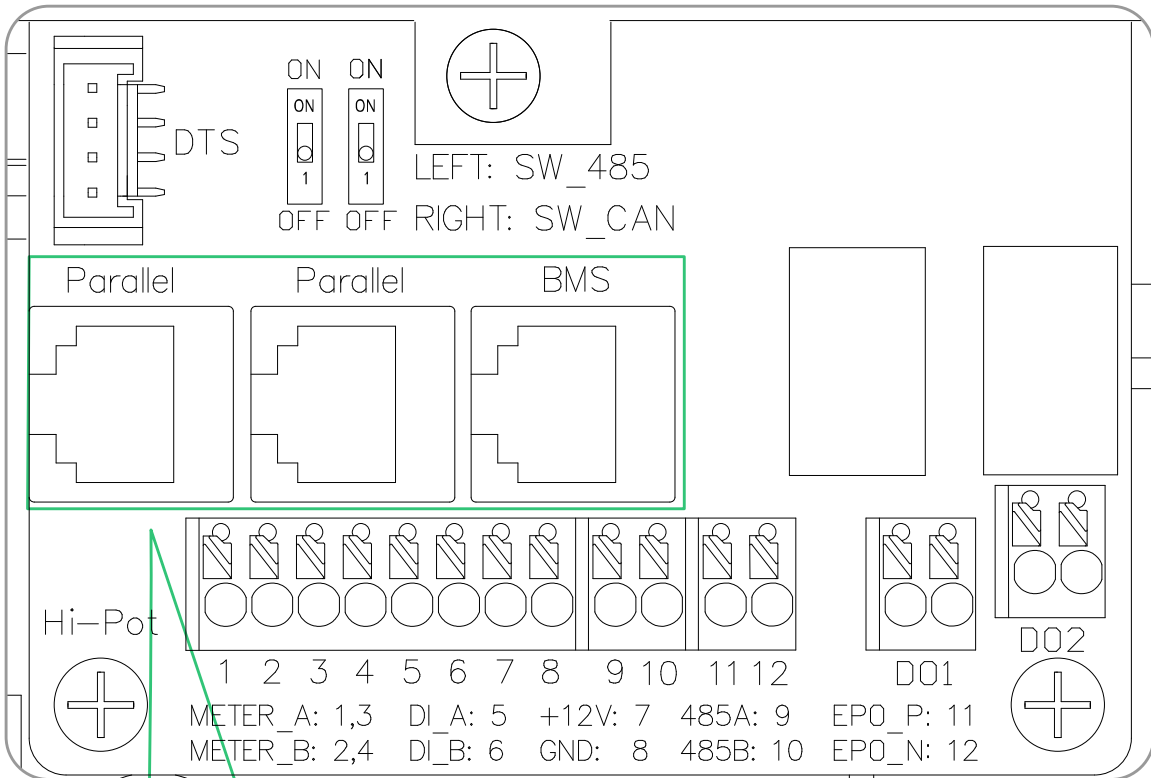

Label	Description
Parallel (CANH, CANL, 485B_1, 485A_1, 485B_2, 485A_2)	For parallel operation.
BMS (NTC+, NTC-, CANH, CANL, 485A, 485B)	For Li-ion batteries, communication is via CAN or RS485. For lead-acid batteries, the temperature is monitored via a sensor through NTC+ and NTC-.
SW_485 (ON, OFF)	120 Ohm termination resistor for parallel operation.
SW_CAN (ON, OFF)	120 Ohm termination resistor for parallel operation.
Meter (485A1, 485B1, 485A2, 485B2)	For the smart meter. One is connected to the grid side, and the other is connected to the third-party inverter.
DI (DI_A, DI_B)	Dry contact input of external bypass contactor.
+12V/GND	Reserved.
EPO_P/EPO_N	For external Emergency Power Off switch.
DO1 (NO1, COM1)	Dry contact output. The DO1 can be set to one of the functions as follows: Earth Fault Alarm, Load Control, and Generator Control.
DO2 (NO2, COM2)	Dry contact output. The DO2 will control the bypass contactor under certain logic.

4G and Wi-Fi Connection

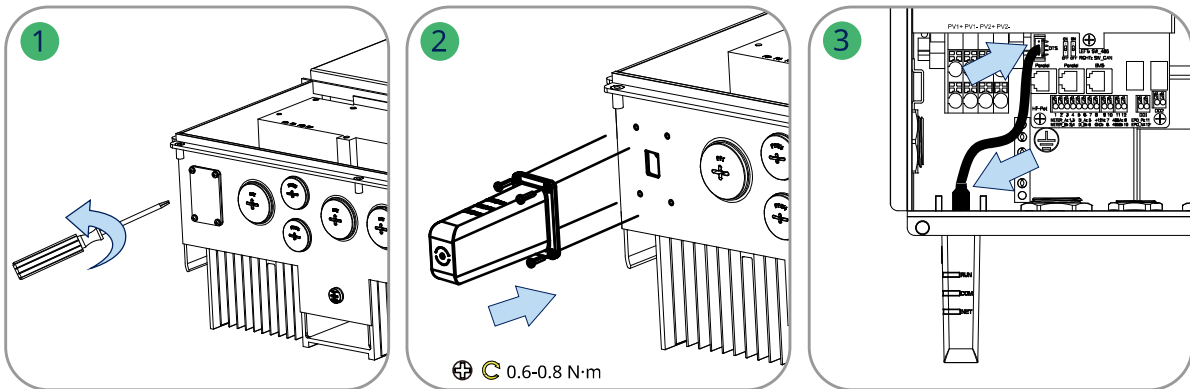

Ethernet Connection

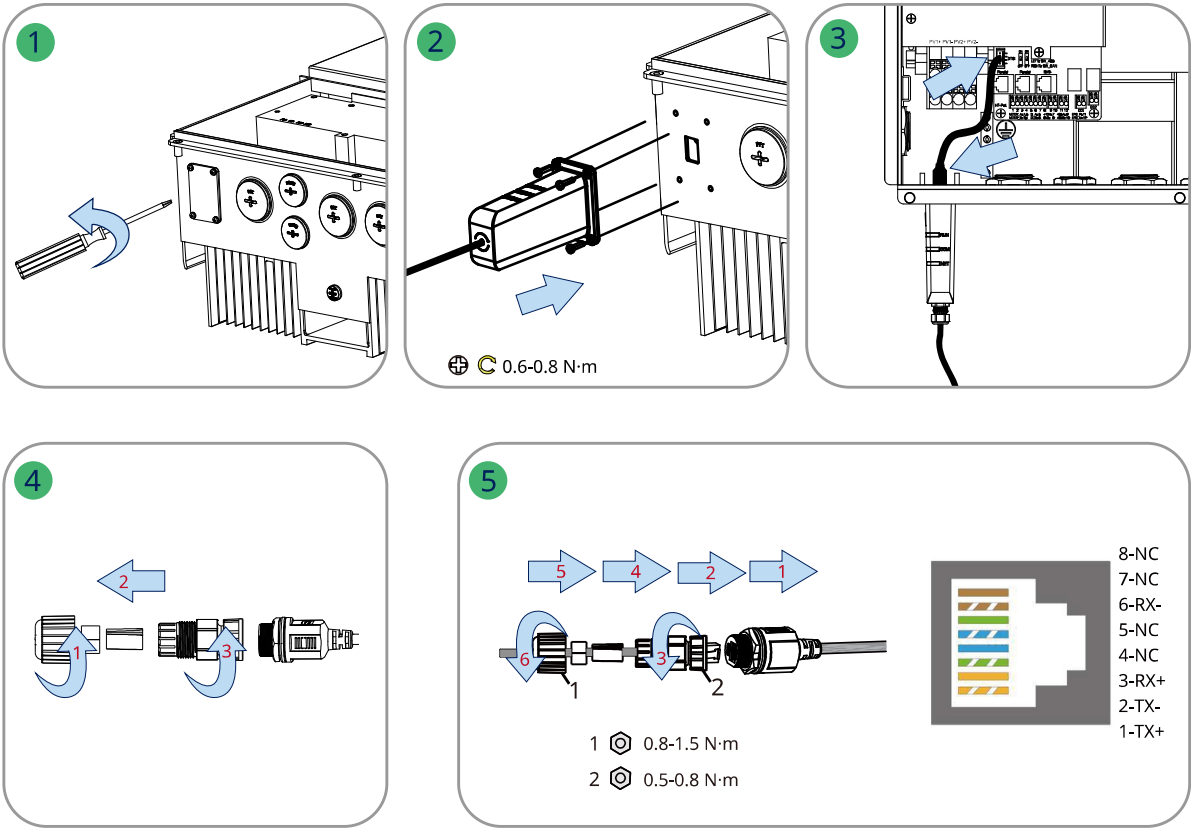

Step 6 Installing the Wiring Box Cover

After the cables are firmly and correctly connected, install the wiring box cover.

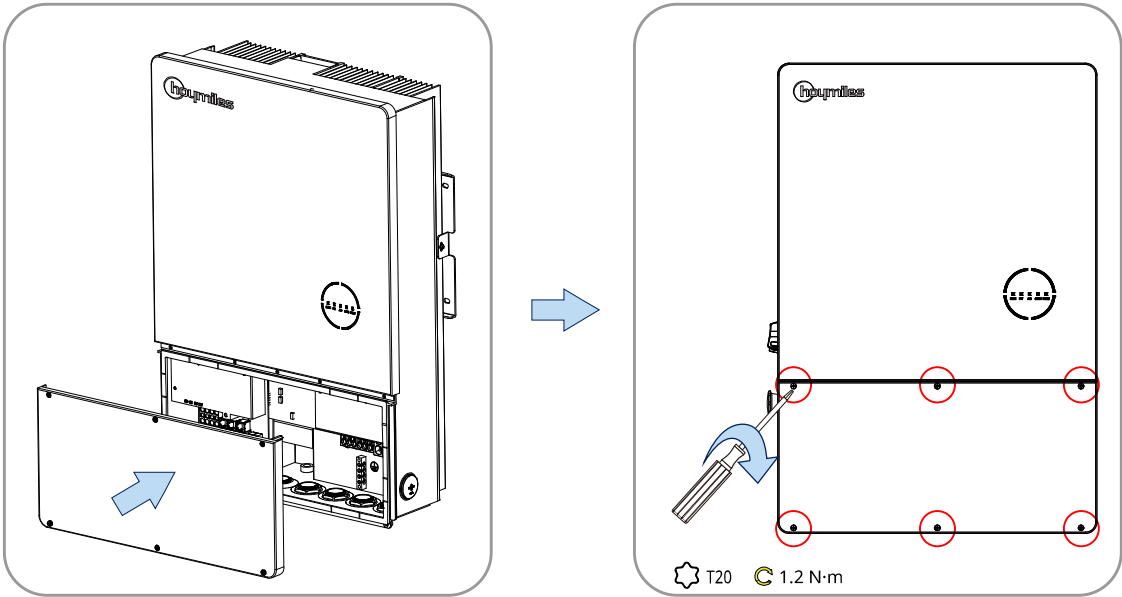

8 DTS Online Setting



1. Search “Hoymiles” in the App Store (iOS) or the Play Store (Android), or scan the QR code to download the Hoymiles Installer App.
2. Open the App and log in with your installer account and password. For new Hoymiles installers, please apply for an installer account from your distributor in advance.
3. Use the App to connect to the DTS.
 - (a) Open the Installer App on smartphone/tablet and log in. Tap on “O&M” at the bottom of the page, and then tap “Network Config”.

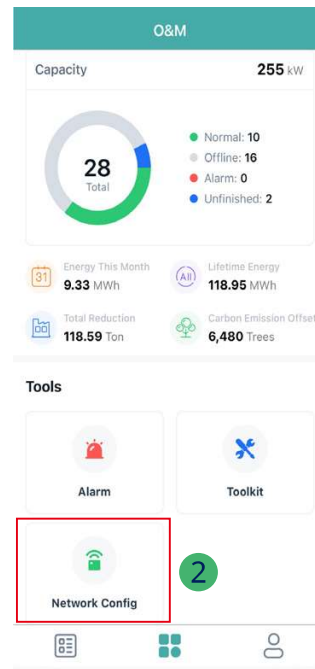
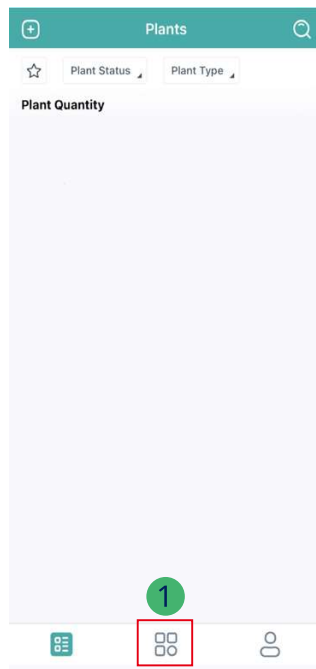

(b) Select the DTS's wireless network and tap on "Connect". (The network name of the DTS consists of DTS and product serial number, and the default password is **ESS12345**.)

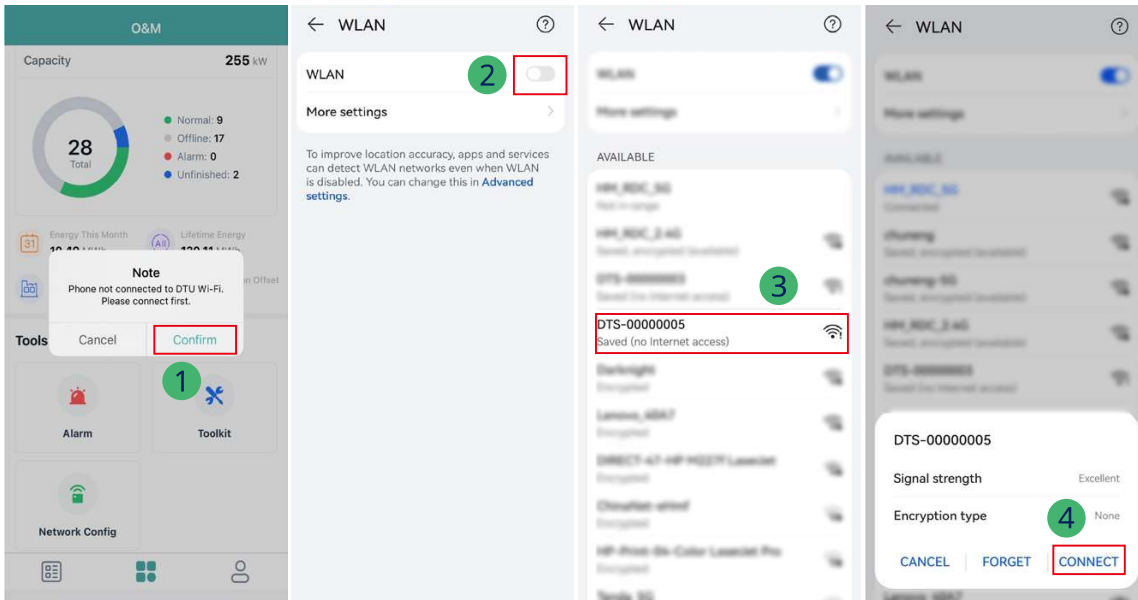

4. Network configuration.

(a) Upon successful connection, tap on "Network Config" again and access the Network Configuration page.

(b) Select the router Wi-Fi and enter the password.

(c) Tap on "Send to DTU".

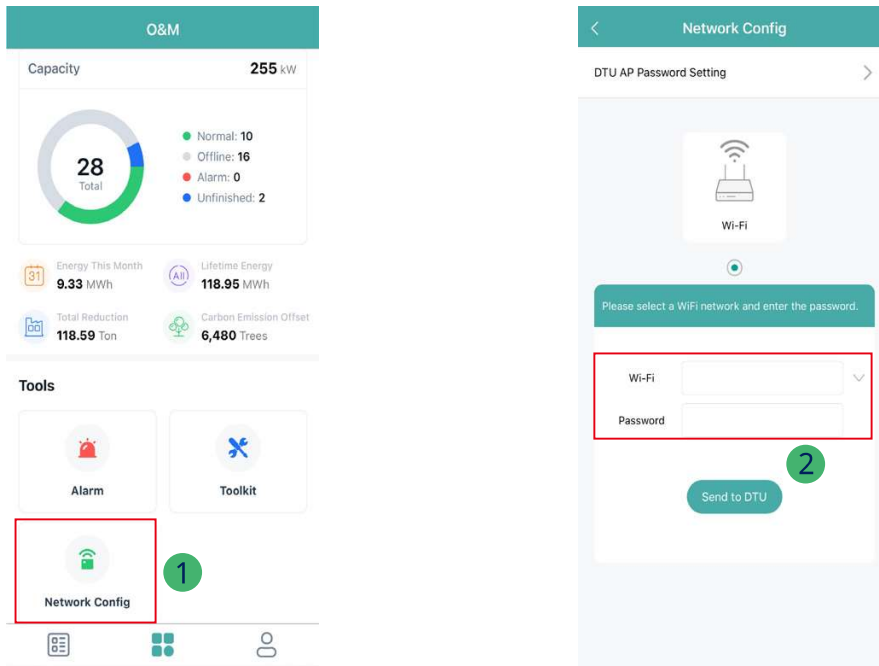

5. Check the DTS indicator for a solid blue light, which signifies a successful connection. The network configuration takes about 1 minute, please be patient. If the network is not connected, please check the internet as instructed.

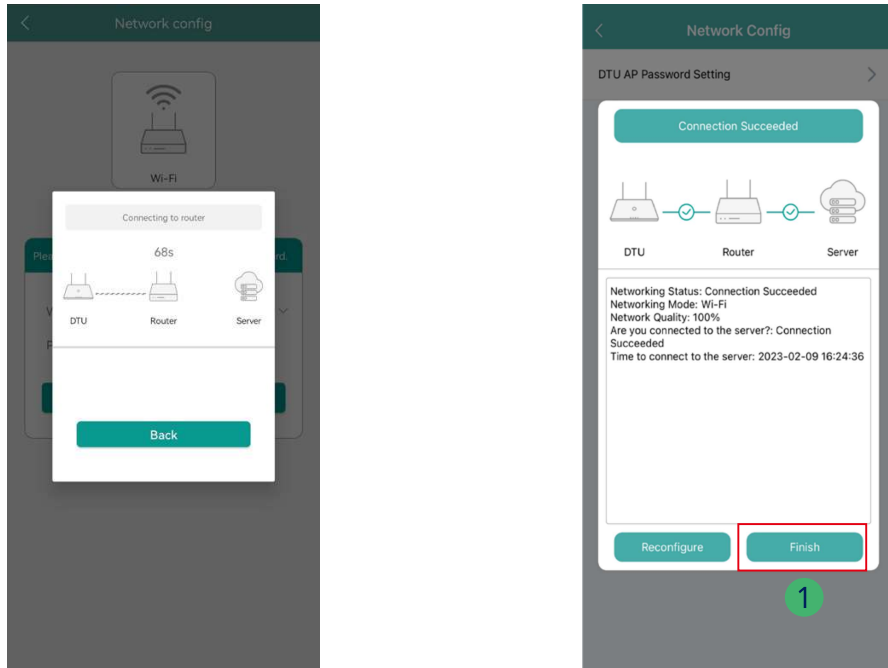

9 System Commissioning of Wireless Access Point (AP) Connection

1. Connect the wireless network of DTU. Open the App, and tap “Toolkit → Meter Location” to configure the grid side meter. The serial number (SN) can be entered manually or identified through scanning the QR code.

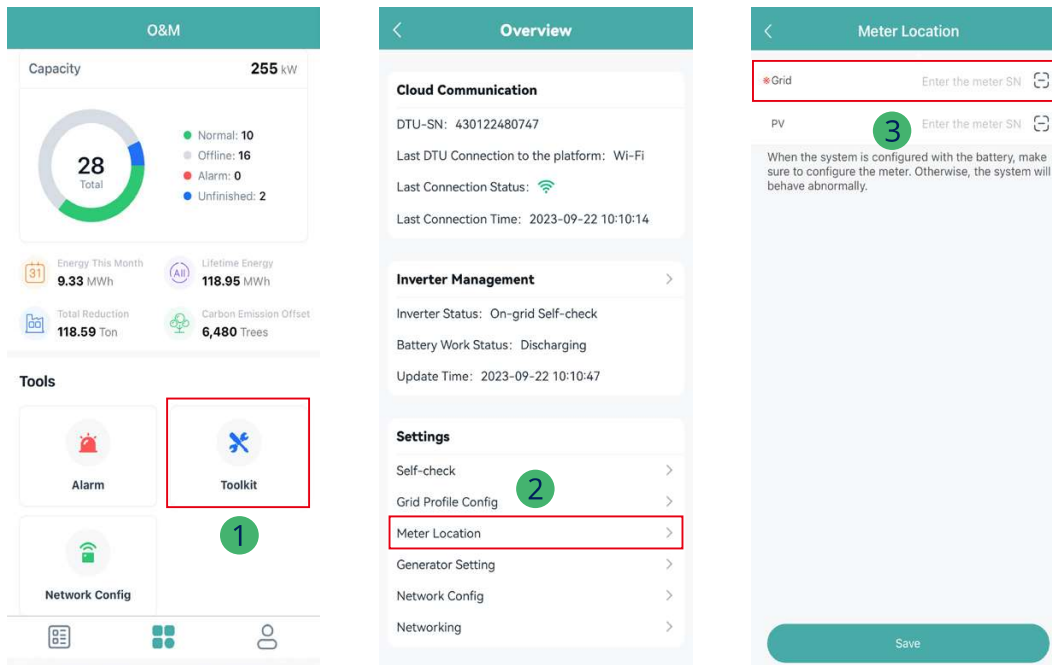

2. Tap “Grid Profile Config → ESS Advanced Config → Meter Model” to choose “Two-phase Meter”, and tap “Save”.

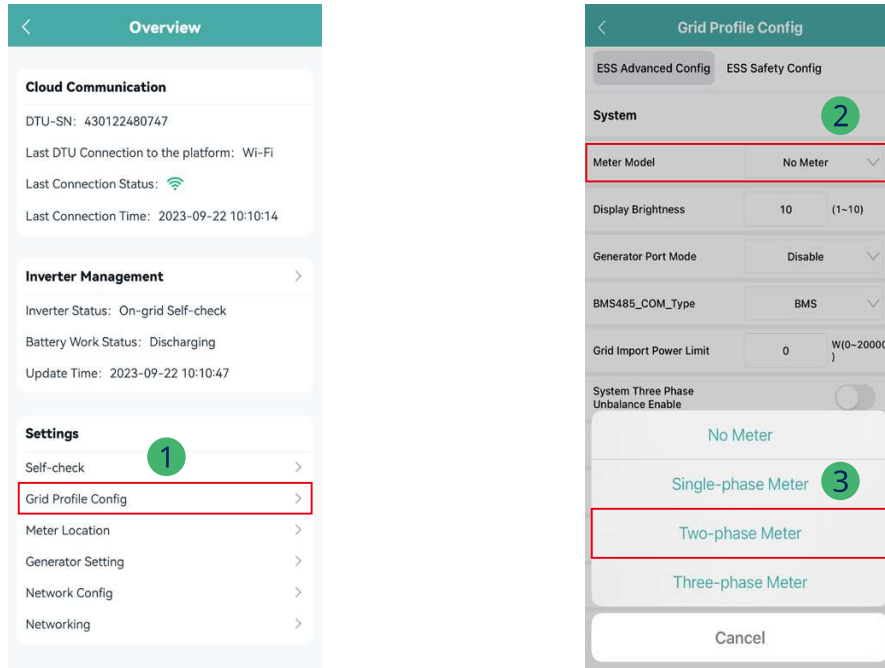

3. Tap “Inverter Management → Battery Setting” to set battery type, BMS protocol, and battery capacity, and tap “Save”. (The default setting is “No battery”.)

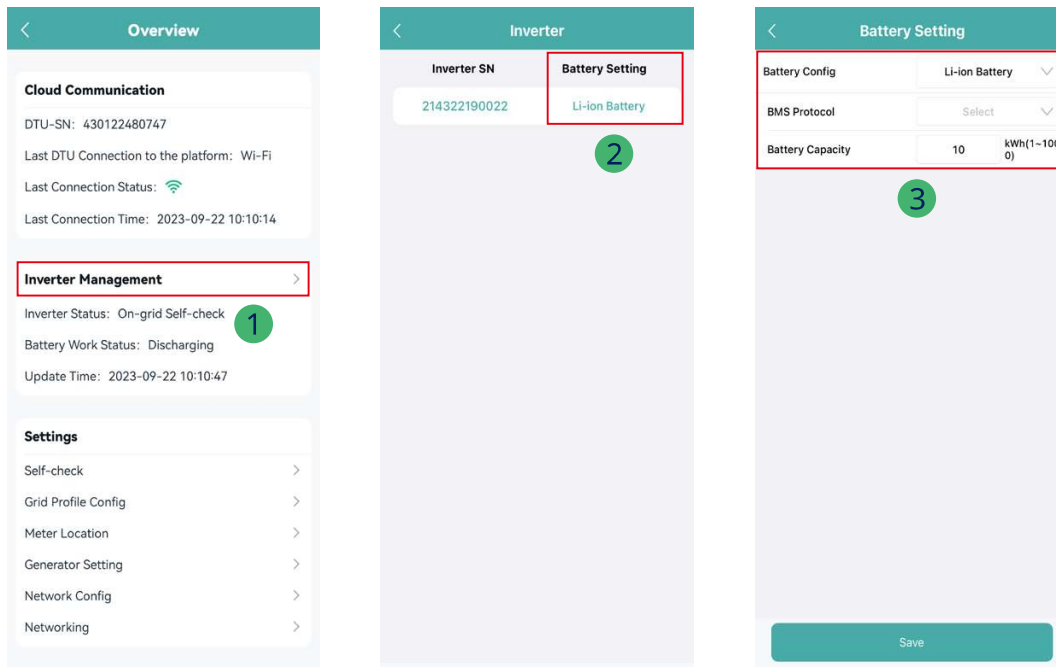

4. Tap “Generator Setting”, choose the corresponding option according to whether the device connected to the GEN port is “Generator” or “Inverter”, and tap “Save”. (The default option is “None”.)

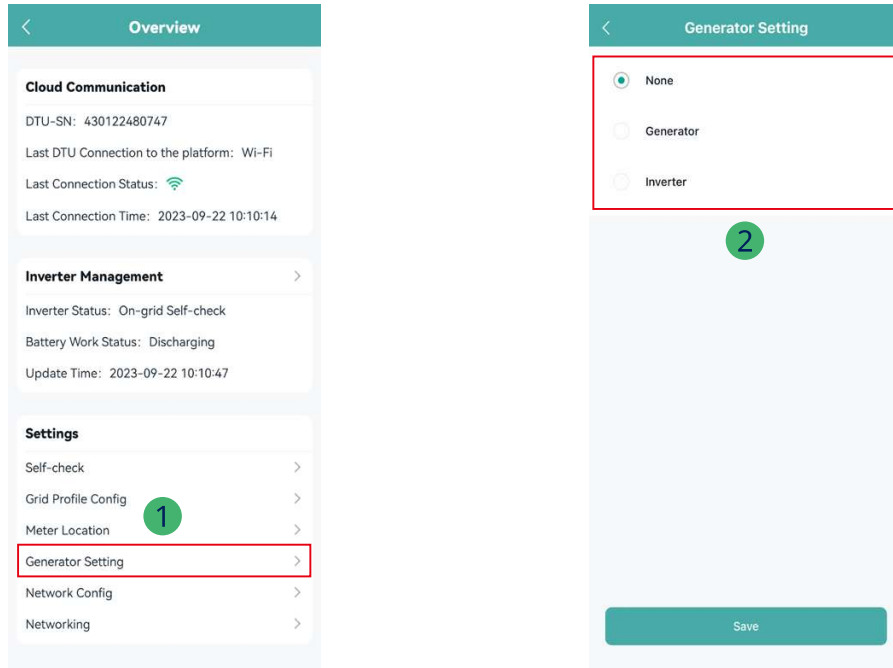

5. Make sure that all cables including DC cables, AC cables, and communication cables are properly connected, and all DC and AC switches are turned on, and then tap “Self-check”.

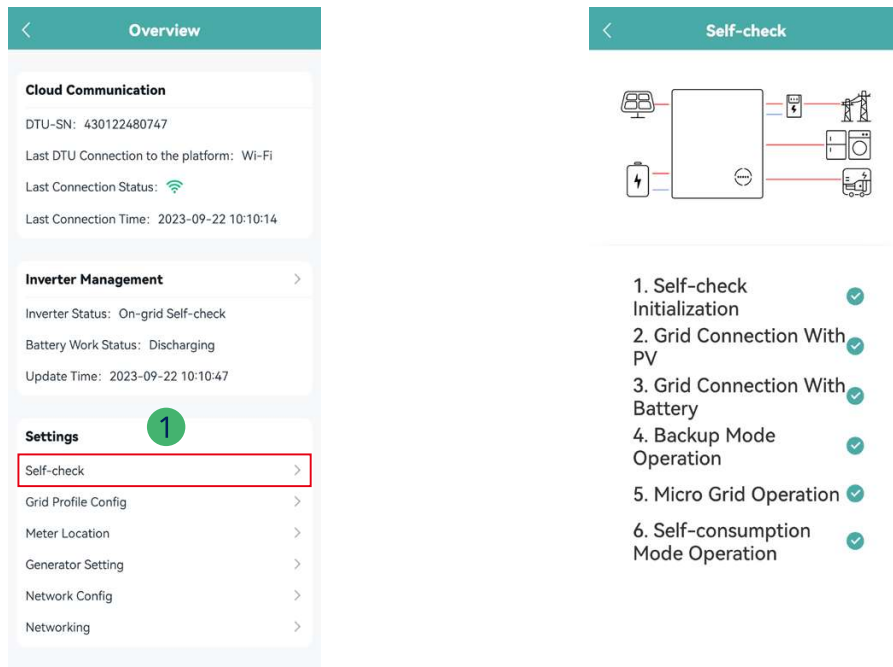



User Manual in the QR code or at
www.hoymiles.com/resources/download/



Installation video in the QR code or at
www.youtube.com/@Hoymiles/videos



Hoymiles Power Electronics Inc.

Add: Floor 6-10, Building 5, 99 Housheng Road, Gongshu District,
Hangzhou 310015, P. R. China

Tel: +86 571 2805 6101

Email: service@hoymiles.com

support@hoymiles.com

www.hoymiles.com

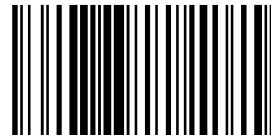

AP040812